

**NOTE:**  
PURSUANT TO SECTION 4 OF ANNEX "A" OF THE REVISED IMPLEMENTING RULES AND REGULATIONS OF RA 9184, APPROVAL BY THE AUTHORIZED DPWH OFFICIALS OF DETAILED ENGINEERING SURVEYS AND DESIGN UNDERTAKEN BY CONSULTANTS NEITHER DIMINISHES THE RESPONSIBILITY OF THE LATTER FOR THE TECHNICAL INTEGRITY OF THE SURVEYS AND DESIGN NOR TRANSFER ANY PART OF THAT RESPONSIBILITY TO THE APPROVING OFFICIALS.  
THE DESIGN CONSULTANT SHALL BE HELD RESPONSIBLE FOR THE FAILURE OF THE FACILITIES / STRUCTURES DUE TO FAULTY DESIGN EXCEPT FOR THE CHANGES MADE WITHOUT THE CONFORMITY OF THE CONSULTANTS.  
DRAWINGS AND SPECIFICATIONS DULY SIGNED, STAMPED OR SEALED, AS INSTRUMENTS OF SERVICE, ARE PROPERTY AND DOCUMENTS OF THE ARCHITECT. WHETHER THE OBJECT FOR WHICH THEY ARE MADE IS EXECUTED OR NOT, IT SHALL BE UNLAWFUL FOR ANY PERSON, WITHOUT THE WRITTEN CONSENT OF THE ARCHITECT OR AUTHOR OF SAID DOCUMENTS, TO DUPLICATE OR TO MAKE COPIES OF SAID DOCUMENTS FOR USE IN THE REPEITION OF AND FOR OTHER PROJECTS OR BUILDINGS, WHETHER EXECUTED PARTLY OR IN WHOLE.

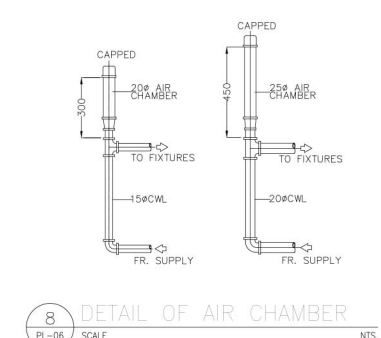
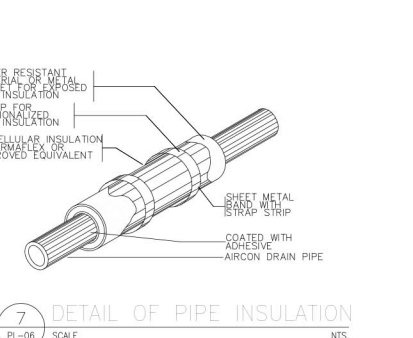
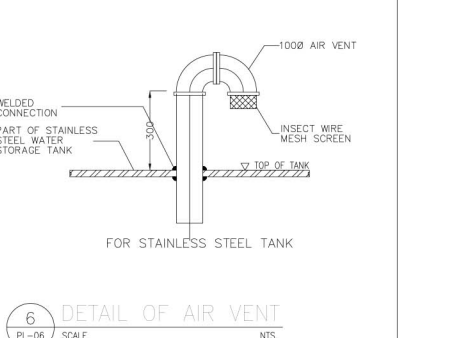

<b>TOKWING</b> CONSTRUCTION CORPORATION 34th Floor, Robinsons Edge, Robinsons Edge, Alabang, Muntinlupa City, Philippines Tel No. (02) 8861 0888 Email: tokwingcorp@tokwing.com.ph		<b>ENRIQUE O. OLANAN &amp; ASSOCIATES</b> ARCHITECTS ENGINEERS CONSULTANTS 305, Kerville Square Condominium, No. 38 Kerville Ave. Loyola Heights, Quezon City Tel No. (02) 7717 3338 Email: eno@enriquo.com		<b>CONSULTANT:</b> CESAR L. MADRAGA SANITARY ENGINEER PRC No. 0000724 VALIDITY: 11/25/2021 PRC No. 25392 DATE: 01/17/2022 PL-06 QUEZON CITY TR. NO. 106-186-110	<b>CHECKED:</b> JOSE MANUEL AGUILARDO SANITARY ENGINEER BUILDING & SPECIAL PROJECTS MANAGEMENT CLUSTER UNIFIED PROJECT MANAGEMENT OFFICE, DPWH	<b>REVIEWED:</b> ATTY. JOHNSON V. DOMINGO PROJECT DIRECTOR BUILDING & SPECIAL PROJECTS MANAGEMENT CLUSTER UNIFIED PROJECT MANAGEMENT OFFICE, DPWH	<b>RECOMMENDING APPROVAL:</b> REYNOR R. IMPERIAL DIRECTOR IV PLANNING AND MANAGEMENT SERVICE CO-HEAD, PSA-BOOM	<b>APPROVED:</b> SOCRATES L. RAMOS DIRECTOR IV ASSISTANT SECRETARY FINANCIAL AND ADMINISTRATIVE SERVICE HEAD, PSA-BOOM	<b>APPROVED:</b> USEC. CLAIR DENNIS B. MAPA, PH. D. NATIONAL STATISTICIAN AND CIVIL REGISTRAR GENERAL PHILIPPINE STATISTICS AUTHORITY	<b>PROJECT:</b> CONSTRUCTION OF FIT-OUT AND LANDSCAPE WORKS FOR THE TWENTY-THREE (23) STOREY PHILIPPINE STATISTICS AUTHORITY (PSA) OFFICE BUILDING WITH COVERED ROOF DECK LOCATION: PSA COMPLEX, EAST AVENUE, DILIMAN, QUEZON CITY	<b>SHEET CONTENT:</b> DETAIL OF ELEVATED POTABLE WATER STORAGE TANK AND PUMP PIPING DETAIL OF ELEVATED NON-POTABLE WATER STORAGE TANK AND PUMP PIPING MISCELLANEOUS DETAILS	<b>DESIGNER:</b> E. OLANAN <b>CAD:</b> AET / ADI <b>CHECKED:</b> RIB / AET <b>DATE:</b> JANUARY 2022	<b>REVISIONS:</b> SYMBOL REMARK DATE 	<b>SHEET NO.</b> PL-06
---	--	--	--	--	--	---	--	---	--	--	--	---	---	---------------------------