

FLOOR FINISH LEGEND :

NEW FINISHES	
F-1	BARE STRUCTURAL CONCRETE SLAB DEPRESSED 50MM TO RECEIVE TOPPING AND FINISH
F-2	600mm x 600mm CARPET TILES
F-3	600mm x 600mm x 8mm THK NON-SKID FLOOR TILE
F-4	600mm x 600mm x 8mm THK POLISHED FLOOR TILE
F-5	RUBBERIZED MAT FLOORING
F-6	SIMULATED WOOD TILES
F-7	600mm x 600mm x 10mm THK POLISHED GRANITE FLOOR TILE
EXISTING FINISHES	
EX-01	POLYURETHANE-BASED EPOXY FLOOR COATING
EX-02	EPOXY TANK LINING
EX-03	CEMENT-BASED NON-SKID WAFFLE TILE
EX-04	WET-INSTALLED 20mm THK FLAMED GRANITE SLAB (PROVIDE SEALER)
EX-05	TROWEL FINISH WITH PENETRATING SEALER AND HARDENER
EX-06	600mm x 600mm x 8mm THK NON-SKID FLOOR TILE
EX-07	600mm x 600mm x 10mm THK POLISHED GRANITE FLOOR TILE
EX-08	600mm x 600mm x 8mm THK POLISHED FLOOR TILE

CEILING FINISHES LEGEND :

NEW FINISHES	
C-1	LOW SHEEN ACRYLIC LATEX PAINT ON SMOOTH RUBBED FINISHED EXPOSED UNDERSIDE OF SLAB/BEAM
C-2	LOW SHEEN ACRYLIC LATEX PAINT ON 12mm THK MOISTURE RESISTANT GYPSUM BOARD ON METAL CEILING JOIST
C-3	600x600 REGULAR ACOUSTIC TILES ON POWDER COATED ALUMINUM T RUNNERS
C-4	POWDER COATED ALUMINUM PANELS ON CONCEALED ALUMINUM RUNNERS
C-5	12mm THK GYPSUM BOARD IN HPL METAL FIN. AND 4mm THK GRAPHICOTE GLASS PANELS ON POWDER COATED ALUMINUM FRAMING WITH 6mm THK ACRYLIC DIFFUSERS
C-6	LOW SHEEN ACRYLIC LATEX PAINT ON 12mm THK GYPSUM BOARD ON METAL CEILING JOIST
C-7	ALUMINUM COMPOSITE CEILING PANEL
C-8	LOW SHEEN ACRYLIC LATEX PAINT ON 12mm THK GYPSUM BOARD HEXAGONAL ACCENT DROP CEILING 1.2m DIA x 150mm THK ON METAL HANGERS
EXISTING FINISHES	
EX-C-1	LOW SHEEN ACRYLIC LATEX PAINT ON SMOOTH RUBBED FINISHED EXPOSED UNDERSIDE OF SLAB/BEAM
EX-C-2	LOW SHEEN ACRYLIC LATEX PAINT ON 12mm THK MOISTURE RESISTANT GYPSUM BOARD ON METAL CEILING JOIST
EX-C-3	LOW SHEEN ACRYLIC LATEX PAINT ON 12mm THK GYPSUM BOARD ON METAL CEILING JOIST

WALL FINISH LEGEND :

EXISTING FINISHES	
EX-W-1	SEMI-GLOSS LATEX PAINT FINISH
EX-W-2	300x600x25mm THK POLISHED HOMOGENOUS WALL TILE
EX-W-3	EPOXY LINING
EX-W-4	LIQUID-APPLIED ELASTOMERIC WALL COATING
EX-W-5	PAINTED FINISH WITH TRAFFIC STRIPE PATTERN
NEW FINISHES	
WF-1	SEMI-GLOSS LATEX PAINT FINISH
WF-2	300x600x25mm THK POLISHED HOMOGENOUS WALL TILE
WF-3	SKIM COAT WALL COATING FINISH
WF-4	ACOUSTIC PADDING
WF-5	4mm THK. COLOR COATED GLASS
WF-6	WOOD VENEER (VERIFY DESIGN ON DETAILS)

PARTITION TYPE LEGEND :

EXISTING PARTITION	
EXP-1	125mm THK CAST-IN-PLACE CONCRETE EXTERIOR WALL
EXP-2	REINFORCED STRUCTURAL CONCRETE WALL
EXP-3	150mm THK CHB 2HR FIRE RATED (FLOOR TO BOTTOM SLAB/BEAM) PLASTERED AND FINISH AS PER WALL FINISH SCHEDULE
EXP-4	150mm THK CHB (FLOOR TO BOTTOM SLAB/BEAM) PLASTERED AND FINISH AS PER WALL FINISH SCHEDULE
NEW PARTITION	
P-1	150mm THK CHB (FLOOR TO BOTTOM SLAB/BEAM) PLASTERED AND FINISH AS PER WALL FINISH SCHEDULE
P-2	100mm THK FULL HT DRY WALL PARTITION w/ 2HR FIRE RATING, GYPSUM BOARD ON METAL FURRING PLASTERED AND FINISHED AS PER WALL FINISH SCHED.
P-3	100mm THK 1.8m HT DRY WALL PARTITION w/ 2HR FIRE RATING, GYPSUM BOARD ON METAL FURRING PLASTERED AND FINISHED AS PER WALL FINISH SCHED.
P-4	100mm THK DRY WALL CLADDING IN 205MM ABOVE FINISH FLOOR LINE (SEE INTERIOR DETAILS)
P-5	12mm THK CLEAR SEMI-FRAMELESS FULL HT TINTED GLASS WALL PARTITION w/ MID-HT FROSTED STICKER BAND

NOTE:
 PURSUANT TO SECTION 4 OF ANNEX "A" OF THE REVISED IMPLEMENTING RULES AND REGULATIONS OF R.A. 9164, APPROVED BY THE AUTHORIZED DPWH OFFICIALS OF DETAILED ENGINEERING SURVEYS AND DESIGN UNDERTAKEN BY CONSULTANTS NEITHER DIMINISHES THE RESPONSIBILITY OF THE LATTER FOR THE TECHNICAL INTEGRITY OF THE SURVEYS AND DESIGN NOR TRANSFER ANY PART OF THAT RESPONSIBILITY TO THE APPROVING OFFICIALS.
 THE DESIGN CONSULTANT SHALL BE HELD RESPONSIBLE FOR THE FAILURE OF THE FACILITY/IES / STRUCTURES DUE TO FAULTY DESIGN EXCEPT FOR THE CHANGES MADE WITHOUT THE CONFORMITY OF THE CONSULTANTS.

DRAWINGS AND SPECIFICATIONS DULY SIGNED, STAMPED OR SEALED, AND INSTRUMENTS OF SERVICE ARE PROPERTY AND DOCUMENTS OF THE ARCHITECT, WHETHER THE OBJECT FOR WHICH THEY ARE MADE IS COMPLETED OR NOT. IT SHALL BE UNLAWFUL FOR ANY PERSON, WITHOUT THE WRITTEN CONSENT OF THE ARCHITECT OR AUTHOR OF SAID DOCUMENTS, TO DUPLICATE OR TO MAKE COPIES OF SAID DOCUMENTS FOR USE IN THE REPEITION OF AND FOR OTHER PROJECTS OR BUILDINGS, WHETHER EXECUTED PARTLY OR IN WHOLE.

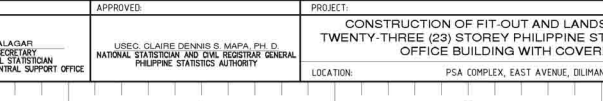
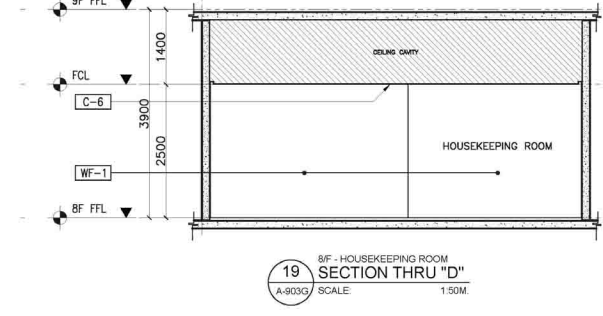
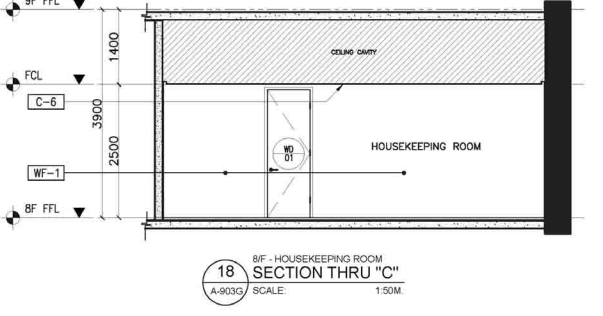
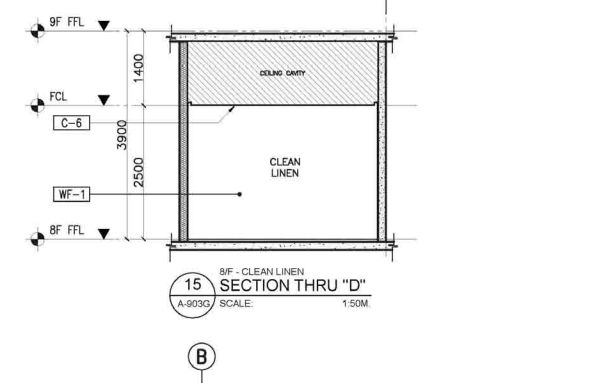
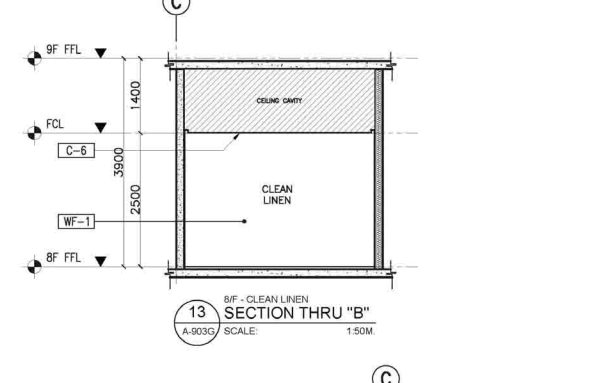
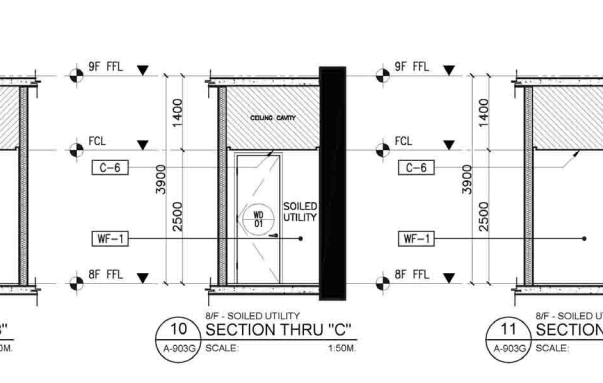
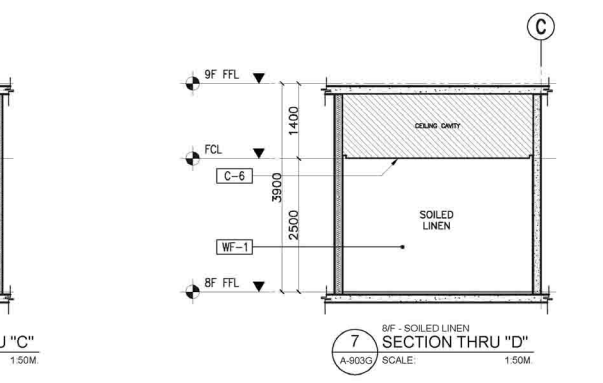
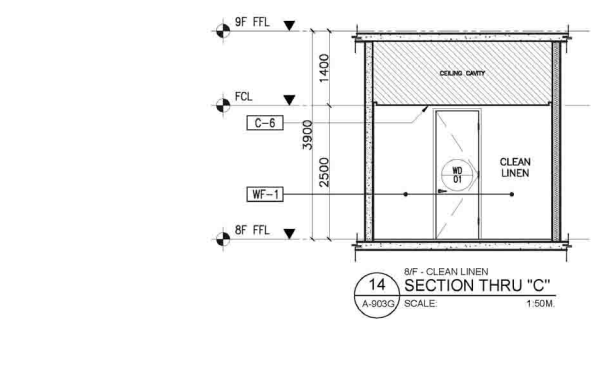
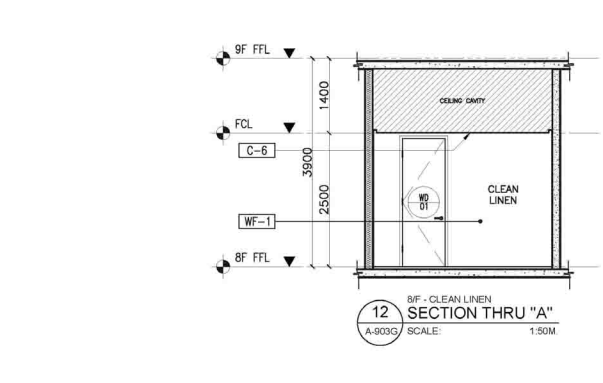
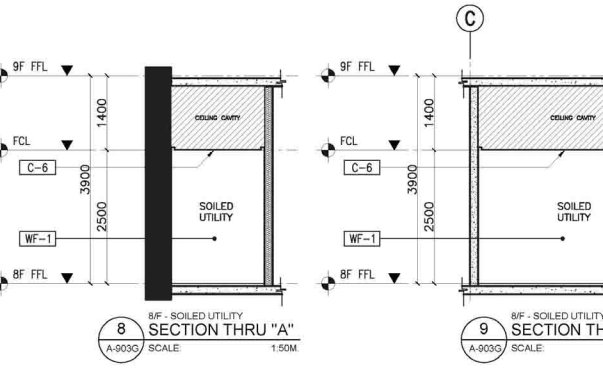
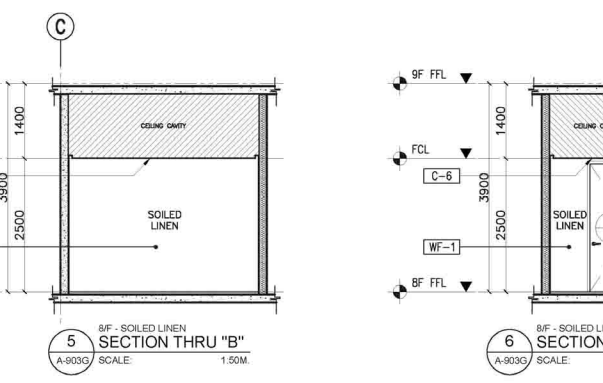
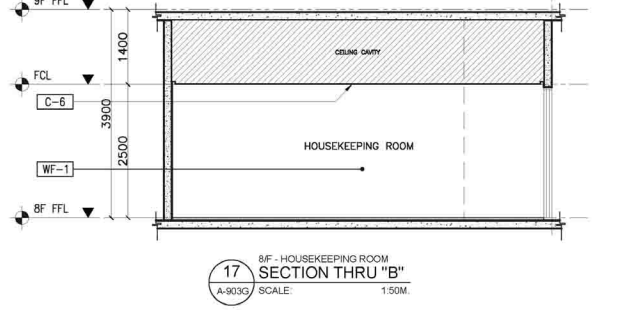
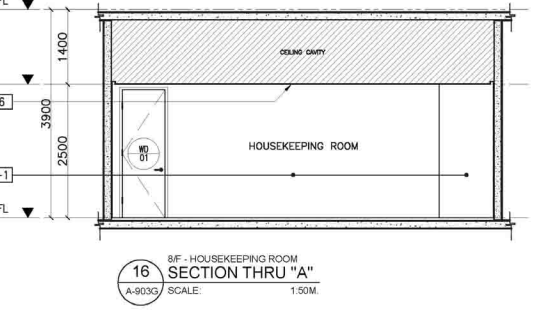
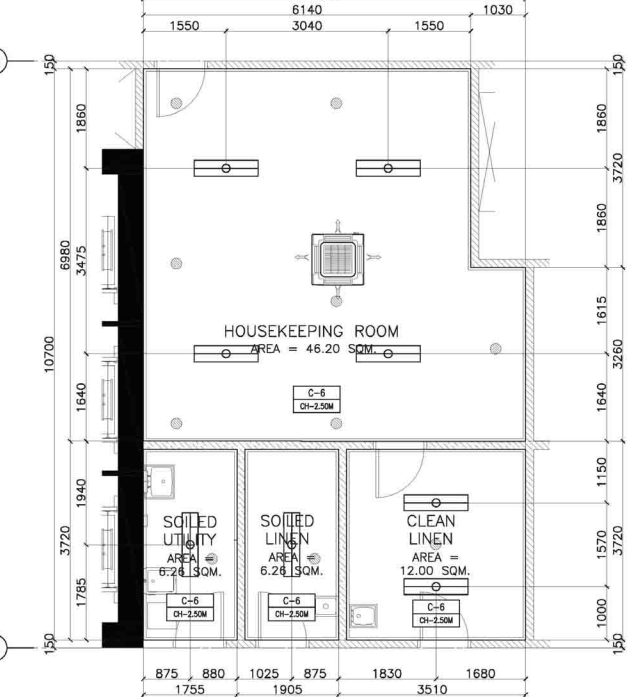
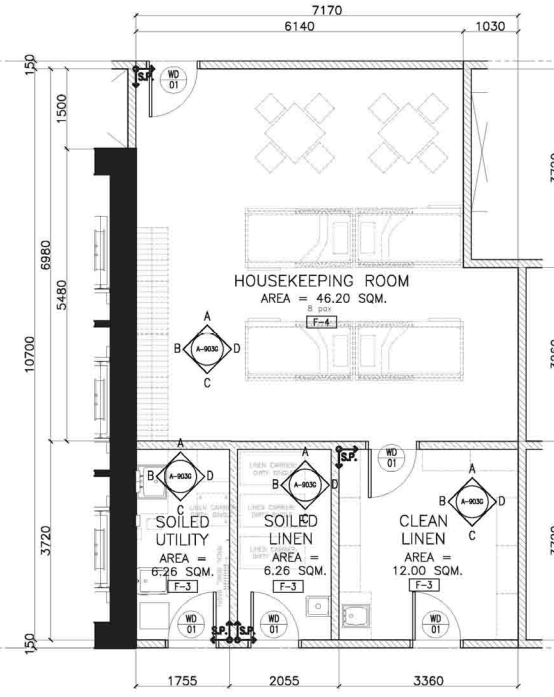
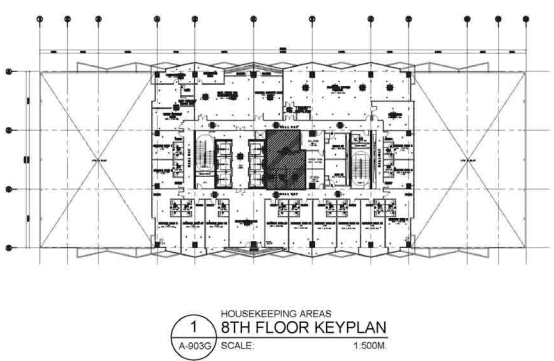

TC TOKWING
 CONSTRUCTION CORPORATION
 10th Floor, 1000 North Ave., Quezon City, Philippines
 Tel No. (632) 886 8958 Email: tokwingcorp@yahoo.com

ENRIQUE O. OLANAN & ASSOCIATES
 ARCHITECTS ENGINEERS CONSULTANTS
 Suite 203, 30th Street Tower, Cebu, Philippines
 Tel No. (632) 886 8958 Email: enoban@enoban.com

CONSULTANT: ENRIQUE O. OLANAN
PROJECT MANAGER: JOSE MANUEL AGUILARDO
PROJECT DIRECTOR: JOSE MANUEL AGUILARDO
UNIFIED PROJECT MANAGEMENT OFFICE, DPWH

CHECKED: JOSE MANUEL AGUILARDO
REVIEWED: ATTY. JOHNSON V. DOMINCO
RECOMMENDING APPROVAL: REYNOR R. IMPERIAL
UNIFIED PROJECT MANAGEMENT OFFICE, DPWH

APPROVED: LEO B. MALAGAR
 DEPUTY NATIONAL STATISTICIAN
 CIVIL REGISTRATION & GENERAL SUPPORT OFFICE
NATIONAL STATISTICS AND CIVIL REGISTRATION AUTHORITY

PROJECT: CONSTRUCTION OF FIT-OUT AND LANDSCAPE WORKS FOR THE TWENTY-THREE (23) STOREY PHILIPPINE STATISTICS AUTHORITY (PSA) OFFICE BUILDING WITH COVERED ROOF DECK
LOCATION: PSA COMPLEX, EAST AVENUE, DILIMAN, QUEZON CITY

DESIGNER: E. OLANAN
CAO: AET / ADI
CHECKED: RIB / AET
DATE: MAY 2021

REVISIONS: SYMBOL, REMARK, DATE
SHEET CONTENT: 8TH FLOOR DETAILS
SHEET NO.: A-903G

FLOOR FINISH LEGEND :	
NEW FINISHES	
F-1	BARE STRUCTURAL CONCRETE SLAB DEPRESSED 50mm TO RECEIVE TOPPING AND FINISH
F-2	600mm x 600mm CARPET TILES
F-3	600mm x 600mm x 8mm THK NON-SKID FLOOR TILE
F-4	600mm x 600mm x 8mm THK POLISHED FLOOR TILE
F-5	RUBBERIZED MAT FLOORING
F-6	SIMULATED WOOD TILES
F-7	600mm x 600mm x 10mm THK POLISHED GRANITE FLOOR TILE
EXISTING FINISHES	
EX-01	POLYURETHANE-BASED EPOXY FLOOR COATING
EX-02	EPOXY TANK LINING
EX-03	CEMENT-BASED NON-SKID WAFFLE TILE
EX-04	WET-INSTALLED 20mm THK FLAMED GRANITE SLAB (PROVIDE SEALER)
EX-05	TROWEL FINISH WITH PENETRATING SEALER AND HARDENER
EX-06	600mm x 600mm x 8mm THK NON-SKID FLOOR TILE
EX-07	600mm x 600mm x 10mm THK POLISHED GRANITE FLOOR TILE
EX-08	600mm x 600mm x 8mm THK POLISHED FLOOR TILE

CEILING FINISHES LEGEND :	
NEW FINISHES	
C-1	LOW SHEEN ACRYLIC LATEX PAINT ON SMOOTH RUBBED FINISHED EXPOSED UNDERSIDE OF SLAB/BEAM
C-2	LOW SHEEN ACRYLIC LATEX PAINT ON 12mm THK MOISTURE RESISTANT GYPSUM BOARD ON METAL CEILING JOIST
C-3	600x600 REGULAR ACOUSTIC TILES ON POWDER COATED ALUMINUM T RUNNERS
C-4	POWDER COATED ALUMINUM PANELS ON CONCEALED ALUMINUM RUNNERS
C-5	12mm THK GYPSUM BOARD IN HPL METAL FIN. AND 4mm THK GRAPHICOTE GLASS PANELS ON POWDER COATED ALUMINUM FRAMING WITH 6mm THK ACRYLIC DIFFUSERS
C-6	LOW SHEEN ACRYLIC LATEX PAINT ON 12mm THK GYPSUM BOARD ON METAL CEILING JOIST
C-7	ALUMINUM COMPOSITE CEILING PANEL
C-8	LOW SHEEN ACRYLIC LATEX PAINT ON 12mm THK GYPSUM BOARD HEXAGONAL ACCENT DROP CEILING 1.2m DIA x 150mm THK ON METAL HANGERS
EXISTING FINISHES	
EX-C-1	LOW SHEEN ACRYLIC LATEX PAINT ON SMOOTH RUBBED FINISHED EXPOSED UNDERSIDE OF SLAB/BEAM
EX-C-2	LOW SHEEN ACRYLIC LATEX PAINT ON 12mm THK MOISTURE RESISTANT GYPSUM BOARD ON METAL CEILING JOIST
EX-C-3	LOW SHEEN ACRYLIC LATEX PAINT ON 12mm THK GYPSUM BOARD ON METAL CEILING JOIST

WALL FINISH LEGEND :	
EXISTING FINISHES	
EX-W-1	SEMI-GLOSS LATEX PAINT FINISH
EX-W-2	300x600x25mm THK POLISHED HOMOGENOUS WALL TILE
EX-W-3	EPOXY LINING
EX-W-4	LIQUID-APPLIED ELASTOMERIC WALL COATING
EX-W-5	PAINTED FINISH WITH TRAFFIC STRIPE PATTERN
NEW FINISHES	
WF-1	SEMI-GLOSS LATEX PAINT FINISH
WF-2	300x600x25mm THK POLISHED HOMOGENOUS WALL TILE
WF-3	SKIM COAT WALL COATING FINISH
WF-4	ACOUSTIC PADDING
WF-5	4mm THK. COLOR COATED GLASS
WF-6	WOOD VENEER (VERIFY DESIGN ON DETAILS)

PARTITION TYPE LEGEND :	
EXISTING PARTITION	
EXP-1	125mm THK CAST-IN-PLACE CONCRETE EXTERIOR WALL
EXP-2	REINFORCED STRUCTURAL CONCRETE WALL
EXP-3	150mm THK CHB 2HR FIRE RATED (FLOOR TO BOTTOM SLAB/BEAM) PLASTERED AND FINISH AS PER WALL FINISH SCHEDULE
EXP-4	150mm THK CHB IN DOOR TO BOTTOM SLAB/BEAM PLASTERED AND FINISH AS PER WALL FINISH SCHEDULE
NEW PARTITION	
P-1	150mm THK CHB (FLOOR TO BOTTOM SLAB/BEAM) PLASTERED AND FINISH AS PER WALL FINISH SCHEDULE
P-2	100mm THK FULL HT DRY WALL PARTITION w/ 2HR FIRE RATING, GYPSUM BOARD ON METAL FURRING PLASTERED AND FINISHED AS PER WALL FINISH SCHED.
P-3	100mm THK 1.8m HT DRY WALL PARTITION w/ 2HR FIRE RATING, GYPSUM BOARD ON METAL FURRING PLASTERED AND FINISHED AS PER WALL FINISH SCHED.
P-4	100mm THK DRY WALL CLADDING IN 205MM ABOVE FINISH FLOOR LINE (SEE INTERIOR DETAILS)
P-5	12mm THK CLEAR SEMI-FRAMELESS FULL HT TEMPERED GLASS WALL PARTITION w/ MID-HT FROSTED STICKER BAND

NOTE:
 PURSUANT TO SECTION 4 OF ANNEX "A" OF THE REVISED IMPLEMENTING RULES AND REGULATIONS OF R.A. 9164, APPROVAL BY THE AUTHORIZED DPWH OFFICIALS OF DETAILED ENGINEERING SURVEYS AND DESIGN UNDERTAKEN BY CONSULTANTS WITHIN MANAGES THE RESPONSIBILITY OF THE LATTER FOR THE TECHNICAL INTEGRITY OF THE SURVEYS AND DESIGN NOT TRANSFER ANY PART OF THAT RESPONSIBILITY TO THE APPROVING OFFICIALS.
 THE DESIGN CONSULTANT SHALL BE HELD RESPONSIBLE FOR THE FAILURE OF THE FACILITY/ES / STRUCTURES DUE TO FAULTY DESIGN EXCEPT FOR THE CHANGES MADE WITHOUT THE CONFORMITY OF THE CONSULTANTS.

DRAWINGS AND SPECIFICATIONS DULY SIGNED, STAMPED OR SEALED, AS INSTRUMENTS OF SERVICE ARE PROPERTY AND DOCUMENTS OF THE ARCHITECT, WHETHER THE OBJECT FOR WHICH THEY ARE MADE IS EXECUTED OR NOT. IT SHALL BE UNLAWFUL FOR ANY PERSON, WITHOUT THE WRITTEN CONSENT OF THE ARCHITECT OR AUTHOR OF SAID DOCUMENTS, TO DUPLICATE OR TO MAKE COPIES OF SAID DOCUMENTS FOR USE IN THE REPEITION OF AND FOR OTHER PROJECTS OR BUILDINGS, WHETHER EXECUTED PARTLY OR IN WHOLE.

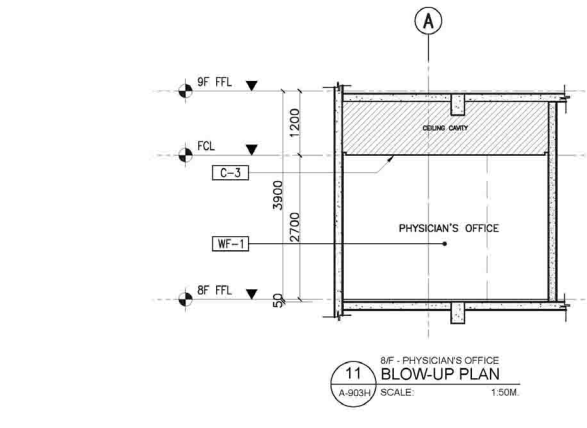
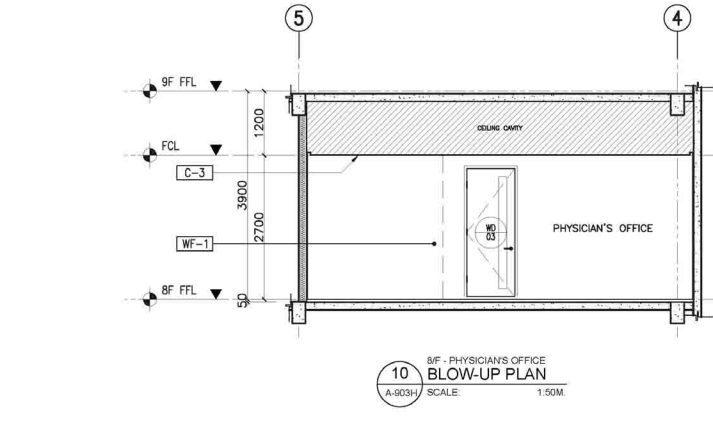
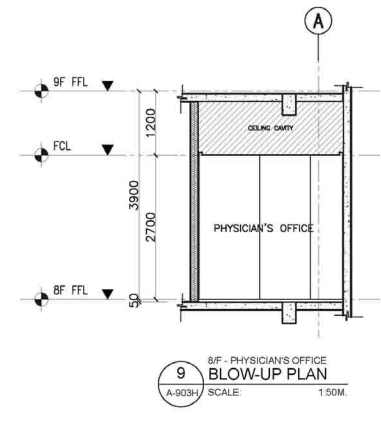
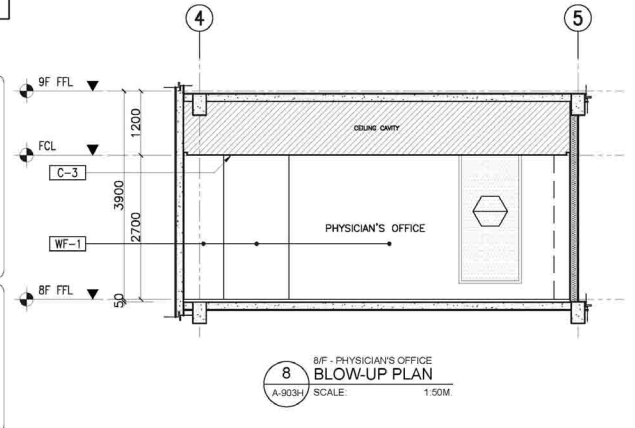
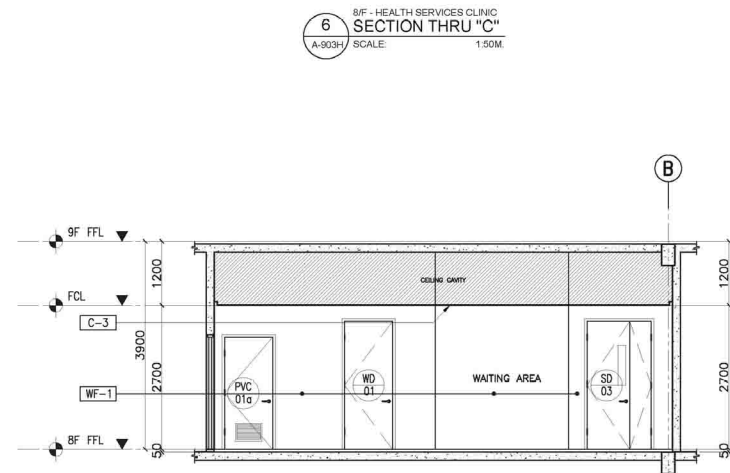
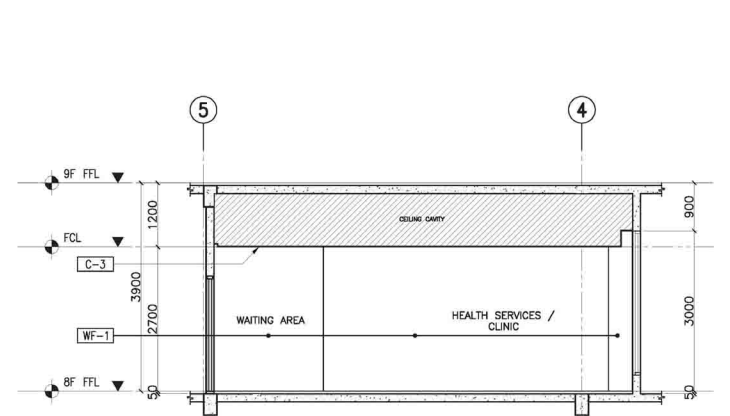
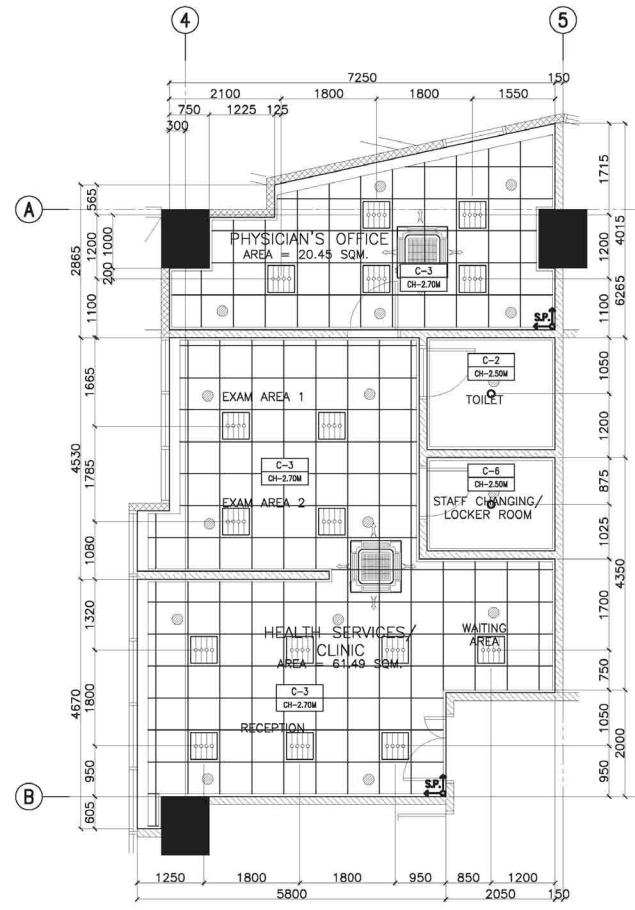
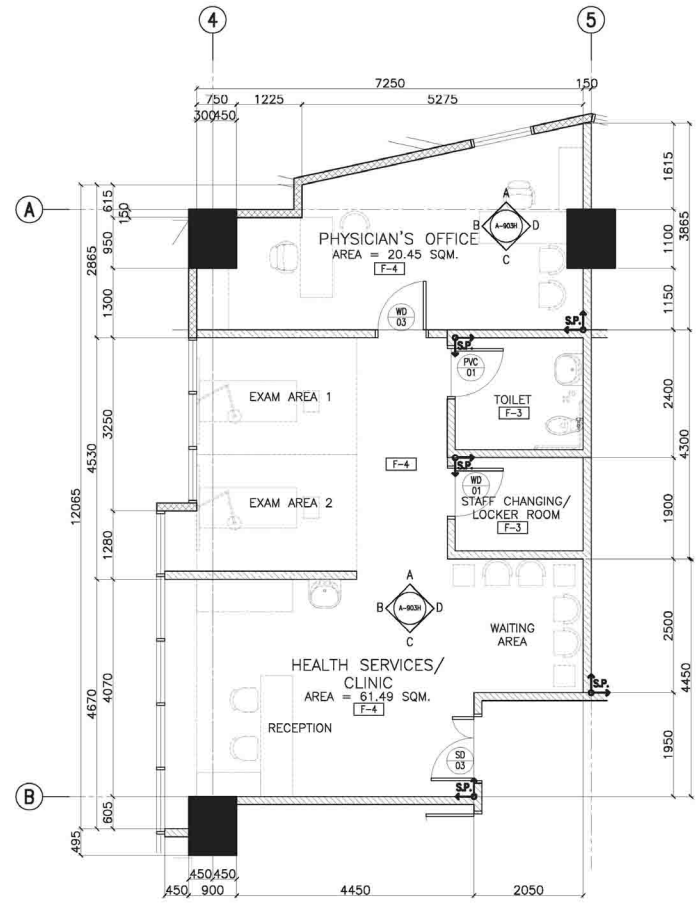
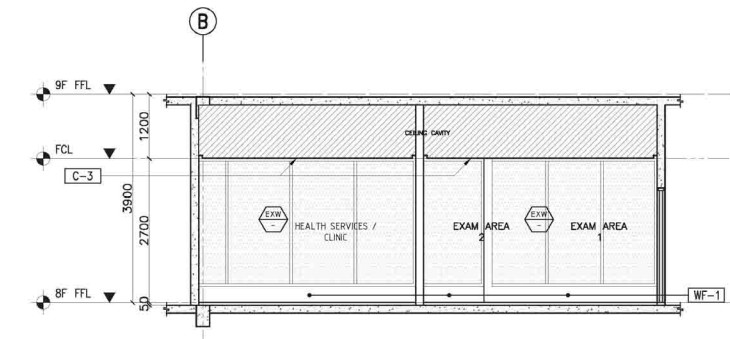
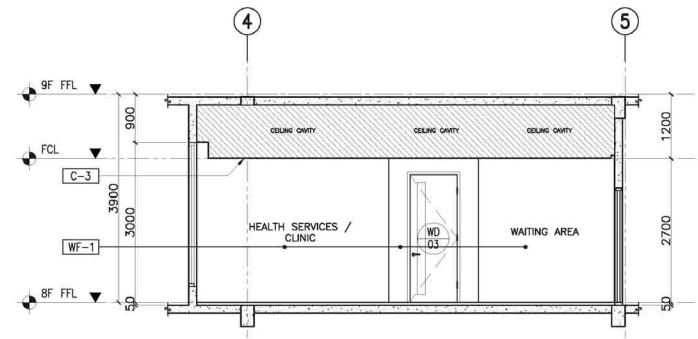
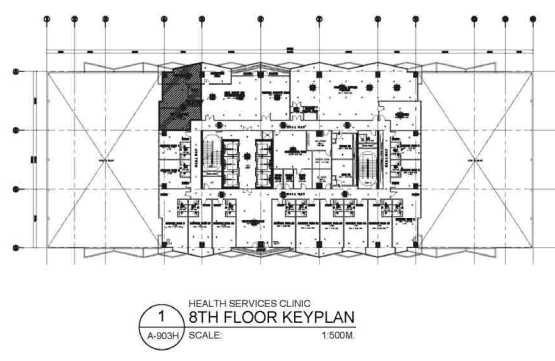

CONSULTANT: ENRIQUE O. OLANAN ARCHITECT	CHECKED: JOSE MANUEL AGUILARDO PROJECT MANAGER	REVIEWED: ATTY. JOHNSON V. DOMINCO DIRECTOR	RECOMMENDING APPROVAL: REYNOR B. IMPERIAL PLANNING AND MANAGEMENT SERVICE CO-HEAD, PSA-BOOM	APPROVED: LEO B. MALAGAR DEPUTY NATIONAL STATISTICIAN NATIONAL STATISTICS AND CIVIL REGISTRAR GENERAL PHILIPPINE STATISTICS AUTHORITY	PROJECT: CONSTRUCTION OF FIT-OUT AND LANDSCAPE WORKS FOR THE TWENTY-THREE (23) STOREY PHILIPPINE STATISTICS AUTHORITY (PSA) OFFICE BUILDING WITH COVERED ROOF DECK LOCATION: PSA COMPLEX, EAST AVENUE, DILIMAN, QUEZON CITY	SHEET CONTENT: 8TH FLOOR DETAILS	DESIGNER: E. OLANAN CAD RIB / AET CHECKED DATE MAY 2021	REVISIONS: SYMBOL REMARK DATE	SHEET NO. A-903H
---	--	---	--	---	---	-------------------------------------	---	--	---------------------